

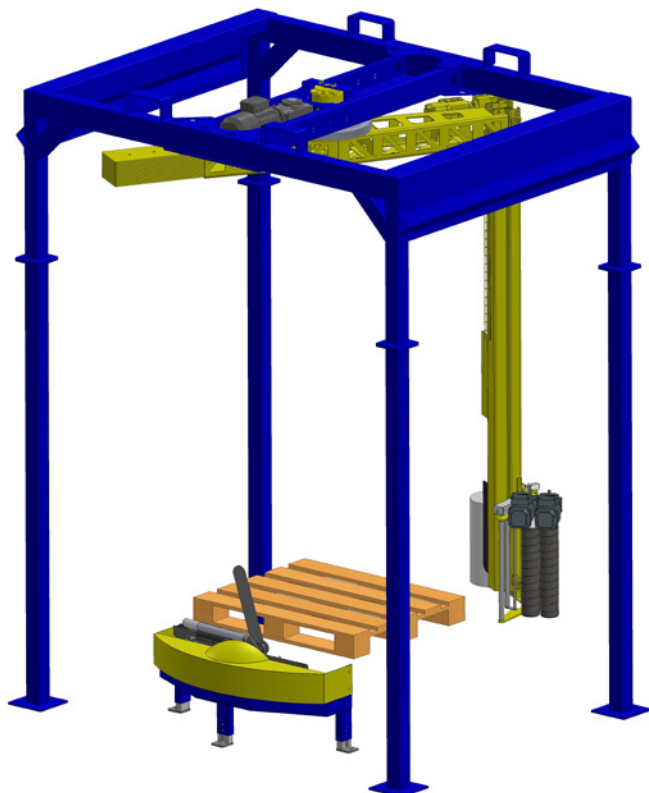

Fully automatic swingarm wrapper



Model: S1500 ISS, medium capacity

- › Handles one of the thinnest film on the market
- › Stretches the film up to 350% in the individual winding phases
- › Operationally efficient, with up to 60 pallets per hour
- › Danish craftsmanship and design ensure the lowest TCO on the market
- › Reduces unnecessary workflows with user-friendly and flexible control
- › 24/7 support from the service center.

Fully automatic swingarm wrapper

Model: S1500 ISS, medium capacity

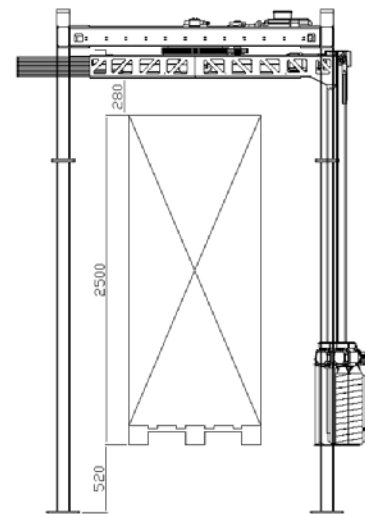

Construction

The S1500 is a swingarm wrapper where the pallet stands still during wrapping while the swingarm carries the film around the pallet. The machine consists of a 4-legged steel profile tube frame, which can be adapted to different types of goods. The construction makes it easy to integrate into existing and new lines.

The swingarm is mounted in a gearwheel ball bearing, which ensures quiet operation. The drive is controlled by a frequency inverter that ensures soft start/stop acceleration as well as the possibility of varying speeds on the swingarm itself.

CONSTRUCTION

Capacity	60 pallets/hour
Pallet size	800 / 1000 / 1200x1200 mm (EU/UK pallet)
Machine weight	1500 kg
Dimensions	2200 x 3000 x h mm
Power supply	3 x 400/ 220 V / 50 Hz /N/ PE (EU) 3x480 / 60 Hz + N + PE (US)
Max. power supply	CEE 16A
Power output	3 kW
Wrapping height	2200 mm (customisable)
Speed	0-26 rpm

Film

Handles all known standard film types. When the film roll is empty, it can be replaced easily without any use of tools.

FILM

Film thickness	10-25 µm
Width (Film)	500 mm (optional 750 mm)
Diameter (Film core)	76 mm
Weight (Film roll)	approx. 17 kg (customisable)

Foil wrapping

All motors are frequency controlled, which gives complete freedom of adjustment over every machine movement.

In this way, the best conditions for film consumption and pallet stability are obtained regardless of the characteristics of the goods, since one is not limited by predetermined or fixed settings.

FILM WRAPPING

Pre-stretch	0-350%
Dual motor system	
Photo-electric cell for automatic height detection	
Full adjustment on film pre-stretch, film tension, overlay and wrappings	
Dust and splash-proof film wrapping	

Welding module

The machine welds are carried out with an ISS welding module and are approved for high-rise warehouses. The welding module is placed up against the conveyor that passes through the machine. But it can also be placed at the top of the swingarm depending on whether the wrapping end should be at the top or bottom of the pallet's cargo.

Welding takes place between a blade and a welding plate and does not affect the goods. The film is cut with a film cutter. The welding time and temperature can be set to ensure the optimal fusion of the film. After welding, the blade runs down, with the direction of travel, without damaging the seam.

LOAD STABILITY

High-rise warehouse approved welds
Eliminates loose 'film tails'
Reinforced assembly via roping
Full adjustment of temperature and time on welding



ISS welding module



Swingarm and wheel ball bearing



Film carriage

Control

The machine's intelligent film control makes it possible to gain 100% control over all parameters in the film wrapping phases. This is done via an operator panel or through signal exchange and applies to speed, film tension, film volume control and density of film overlay. It optimises film consumption and load safety on all types of pallets.

Status and error messages appear in plain text in the operator panel. Manual operation of all functions via HMI.

CONTROL

Control/PLC	Siemens – S7
Frequency inverter	Siemens
Sensors	SICK
Operator panel	Siemens - TP 700C
Programs	User-defined
Password protection	
Stop timings	1100 milliseconds

Energy supply

- › Net type: TN-S
- › ICC: 6 kA
- › Supply disconnection:
Main switch on cabinet
- › Power supply without options:
6,85 kW 8,09 kVA

Electrical cabinet protection

- › Rittal
- › Lock on door
- › Inside cabinet protected IP53
- › Equipotential bonding:
Yes, relevant internal components.

Emergency stop

- › Cat: 1
- › Min. PL = d
- › SRP/CS cat: 3

AIR SUPPLY

Maximum work pressure	6 bar
Minimum work pressure	5 bar
Air quality to	ISO 8573-1
Air flow max	600 L/h
Air consumption pr. Pallet	127 L ±40 L

Ambient condition

- › Type:
Normal industrial environment – indoor.
- › IP-class 54
- › Temperature:
+5°C minimum, +35°C maximum
- › Humidity:
30% minimum, 85% maximum
- › Explosions:
Not intended to be used in ATEX areas
- › Altitude:
Maximum 1000 m above sea level



Maintenance

Yearly ore for every 25.000 pallets full service with monthly preventive maintenance.

Safety related components must be controlled once a year.

Lifetime:

Approx 20 years if maintenance/service is done to instructions.

Safety related components must be controlled once a year.

Operator:

Skilled operator with training and normal physical and mental reaction capability.

Technician:

- › Skilled technician
- › Electrical technician

Options

We can customise the stretch wrapper with the following options:

OPTIONS

Extended pallet wrapping height above 2200 mm

Top sheet dispenser (splash/dustproof)

Top holding plate (can be adjusted to load)

Roping (two-sided reinforced wrapping)

Corner/edge protection

Pallet sizes as desired (1/4 pallets)

Galvanised/stainless steel finish

Cold/frost use

Extended control with conveyor systems/functional machines

Complete all-function conveyor system (rollers, chains and belts/drives)

Automatic film change.

REO-PACK A/S

Kongsdal Havn 4
DK-9550 Mariager
+45 98 58 41 00
www.reo-pack.com

